



# SOCIALITE WHEELCHAIR

Attendant Propelled | Self Propelled

## USER MANUAL



Aspire Socialite  
Attendant Propelled



Aspire Socialite  
Self Propelled

Congratulations and thank you for choosing an Aspire Socialite Wheelchair.

This product has been designed to offer the maximum in comfort, safety and lightweight portability. Aspire Socialite Wheelchairs are suitable for indoor and outdoor use.

**It is important that you read this user manual carefully before using your new wheelchair.**

## TABLE OF CONTENTS

---

1. Symbols Used In This Manual	4
2. Symbols Used On The Product	4
3. Intended Use	5
4. Product Description	5
5. Warnings	6
6. Product Specifications	6
7. List of Components	7
8. Assembly Instructions	8
9. Preliminary Checks	9
10. General Operation	9
11. Adjusting Your Wheelchair	12
12. Optional Accessories	13
13. Troubleshooting	14
14. Care & Maintenance	15
15. Warranty	16
16. Compliance	16
17. Service Maintenance & Customisation	16
18. Recycling Information	16
19. Manufacturer, UK Representative and Importer Details	17

 This product features the CE mark, in compliance with the Medical Devices Regulation 2002 (as amended) Class 1, and the Medical Device Regulation 2017/745

 This product Features the UKCA mark, in compliance with Part II UK MDR 2002 (as amended) Class 1

© Aidacare Pty Ltd 2024

No part of this user manual may be copied, distributed, reproduced, scanned or stored on any electronic database, whether in whole or in part in any form or by any means.

Due care has been taken to ensure all the information contained in this user manual is correct at the time of printing. All measurements, pictures, colours and weight capacities are to be used as a guide only. We reserve the right to modify the design or appearance of any product displayed in this user manual without prior notice.

# 1. SYMBOLS USED IN THIS MANUAL

The symbols below are used throughout this user manual and on the product to identify warnings and important information. It is very important for you to read them and understand them completely.

 **WARNING!** Indicates a potentially hazardous condition/situation. Failure to follow designated procedures can cause either personal injury, component damage or malfunction. On the product, this icon is represented as a black symbol on a white triangle with a black border.













 **ALWAYS!** These actions should be performed as specified. Failure to perform mandatory actions can cause personal injury and/or equipment damage. On the product, this icon is represented as a white infinity symbol on a black dot with a white border.

 **DO NOT!** These actions are prohibited. These actions should not be performed at any time or in any circumstances. Performing a prohibited action can cause personal injury and/or equipment damage. On the product, this icon is represented as a white symbol with a black circle and black slash.

# 2. SYMBOLS USED ON THE PRODUCT



**aspire SOCIALITE WHEELCHAIR** EC REP European Healthcare & Device Solutions (Ireland) Ltd  
 # MWS449820 SN Stratton House, Bishopstown Road, Cork T12 Y9TC Ireland, info@europeandevicesolutions.eu  
 AUSTRALIA | Aidacare Pty Ltd | ABN 40 134 398 833 | Building 3A, 1 Moorebank Avenue, Moorebank NSW 2170 | 1300 133 120 | product@aidacare.com.au  
 UNITED KINGDOM | Aidacare Ltd | Registration 13785408 | Arcadia House, Maritime Walk, Ocean Village, Southampton SO14 3TL | 01622 541235 | info@aidacare.co.uk  
 MADE IN PRC It is recommended that you have this product serviced every 12 months.

-  Product Code
-  Serial Number
-  Manufacturer
-  Importer
-  Country of Manufacture
-  Not Crash Tested
-  CE Mark
-  UKCA Mark
-  Safe Working Load
-  Read User Manual
-  Caution
-  Medical Device
-  Authorised Representative in EU

# 3. INTENDED USE

This product is specifically designed for individuals who, due to a wide variety of reasons, have limited mobility or are unable to walk. This product should be used as a tool to assist with mobility or walking difficulties.

Attendant Propelled Wheelchairs are able to be propelled by an attendant with the push handles. This wheelchair is designed for indoor and limited outdoor use. When used outdoors this wheelchair must remain on sealed, level terrain (examples include but are not limited to shopping centres, medical centres, flat and level footpaths, and environments with accessibility-focused layouts). When using outdoors it is suggested that anti-tip wheels are fitted.

Self Propelled Wheelchairs are able to be propelled by a user with the self-propelling wheels or by an attendant with the push handles. This wheelchair is designed for indoor and limited outdoor use. When used outdoors this wheelchair must remain on sealed, level terrain (examples include but are not limited to shopping centres, medical centres, flat and level footpaths, and environments with accessibility-focused layouts). When using outdoors it is suggested that anti-tip wheels are fitted.

 **WARNING!** This wheelchair is intended to bear the weight of an occupant through its wheels during propulsion and when stationary. It is **NOT** designed to be lifted/carried with an occupant in the seat and doing so may cause serious injury or death.

**WARNING! Transportation in a Vehicle**  
 This wheelchair is NOT designed or tested to carry an occupant for transportation in a motor vehicle. When travelling in a motor vehicle the occupant should sit in the vehicle seat with seatbelt fastened and the wheelchair be folded and securely stored in the luggage compartment.

# 4. PRODUCT DESCRIPTION



The Aspire Socialite AP is an attendant propelled, four wheel wheelchair with a cross folding frame. The product is made from aluminium, so it is light and easy to store or transport. This wheelchair offers great manoeuvrability, stability and it's leg rests are height adjustable for a customised fit.

It is equipped with a padded mesh seat and backrest, push handles, 12 inch rear wheels, swing-away legrests and padded armrests.













The Aspire Socialite SP is a self propelled, four wheel wheelchair with a cross folding frame. The product is made from aluminium, so it is light and easy to store or transport. This wheelchair offers great manoeuvrability, stability and it's leg rests are height adjustable for a customised fit. It is equipped with a padded mesh seat and backrest, push handles, 22 inch rear wheels, swing-away legrests and padded armrests.

## 5. WARNINGS

### MAXIMUM WEIGHT CAPACITY – 115kg / 18st

-  **DO NOT** exceed maximum user weight. This weight limit includes any accessories, shopping or other personal items that may be carried on the chair. The maximum weight capacity is defined with respect to a typical body shape, where body mass is evenly distributed. Users with dysmorphic body shapes or amputees should be assessed by an accredited healthcare professional prior to choosing/using this wheelchair.
-  **DO NOT** stand on the foot plates as the wheelchair may tip forwards. The foot plates are not designed to be a weight bearing surface.
-  **DO NOT** use the wheelchair on escalators, even if accompanied by an attendant.

## 6. PRODUCT SPECIFICATIONS

		ATTENDANT PROPELLED	SELF PROPELLED
Overall Length (mm / in)		1030 / 40.6"	1030 / 40.6"
Overall Width (mm / in)		595 / 23.4"	675 / 26.6"
Overall Height (mm / in)		900 / 35.4"	900 / 35.4"
Seat Depth (mm / in)		430 / 17"	430 / 17"
Seat Width (mm / in)		450 / 17.7"	450 / 17.7"
Anterior Seat Height (mm / in)		475-500 / 18.7" - 19.7"	475-500 / 18.7" - 19.7"
Posterior Seat Height (mm / in)		440 / 17.3"	440 / 17.3"
Backrest Height (mm / in)		410 / 16.1"	410 / 16.1"
Armrest Height (mm / in)		200 / 7.9"	200 / 7.9"
Safe Working Load (kg / st)		115 / 18st	115 / 18st
Rear Wheel (in)		12"	22"
Folded Dimensions D x W x H (mm / in)		650 x 305 x 740 / 25.6" x 12" x 29"	650 X 380 X 740 / 25.6" X 14.9" X 29"

### CHAIR WEIGHTS:



## 7. LIST OF COMPONENTS

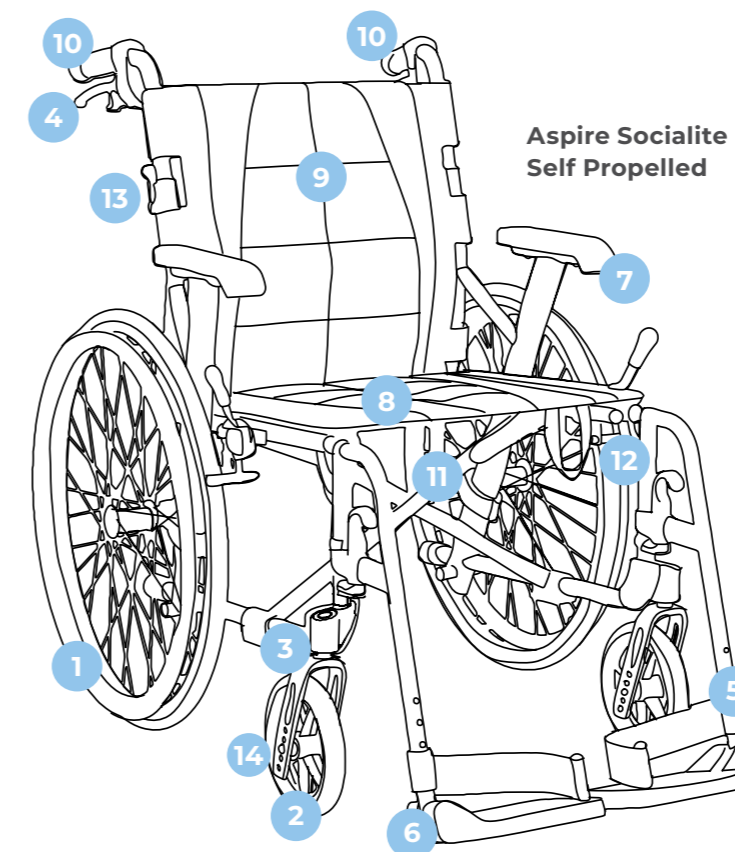
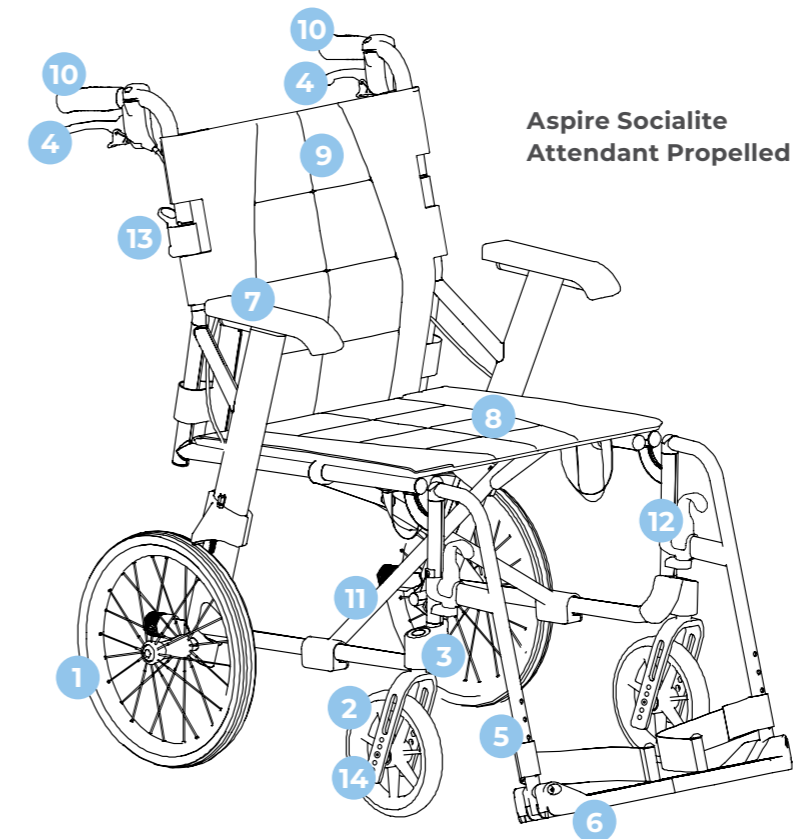

### SOCIALITE

1	12" Rear Wheels (AP) 22" Rear Wheels (SP)
2	7" Front Wheels
3	Wheel fork
4	Attendant Brakes
5	Height Adjustable Legrests
6	Folding Foot Plates
7	Padded Armrests
8	Padded Seat Upholstery
9	Folding Backrest with Padded Upholstery and Carry Pouch
10	Attendant Hand Grips
11	Frame Cross Bar
12	Legrest Removal Lever
13	Folding Backrest Lever
14	Seat Angle Adjustment

## 8. ASSEMBLY INSTRUCTIONS

### BOX CONTAINS:

#### Wheelchair frame fitted with rear wheels

- Wheelchair
- Left Legrest
- Right Legrest
- Allen Keys (4mm, 5mm)
- User Manual

NOTE: AP model shown for illustration.



When opening the carton, ensure it is done in a safe and careful manner. **DO NOT USE** a box cutter or sharp implement as this may damage the product. For WH&S purposes, lay the carton on its side with the top of the carton open and slide the plastic bag out containing the wheelchair.

- 1 Place the wheelchair on levelled ground. Then pushdown on the side rails of the seat until flat.

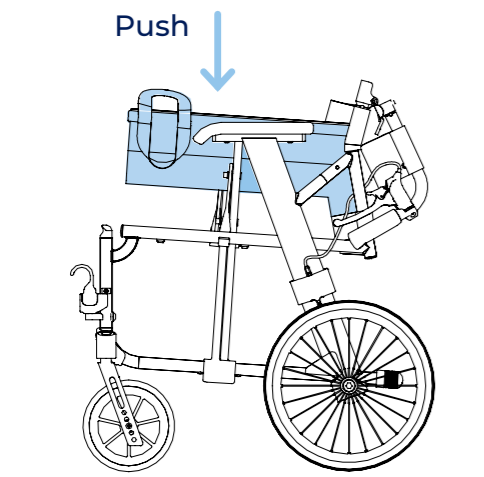

- 2 Flip up and click backrest into place. **IMPORTANT:** Ensure your fingers are kept clear from the pivoting mechanism.

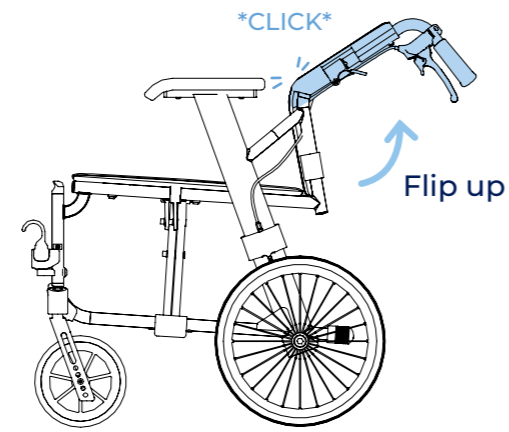

- 3 Wheelchairs come with a left and right legrest.

- a Insert the legrest into the corresponding receiver at a 90° angle (as shown).
- b Pull up and hold the hook, simultaneously rotating the legrest towards the centre until it clicks into place. Repeat for the other side.

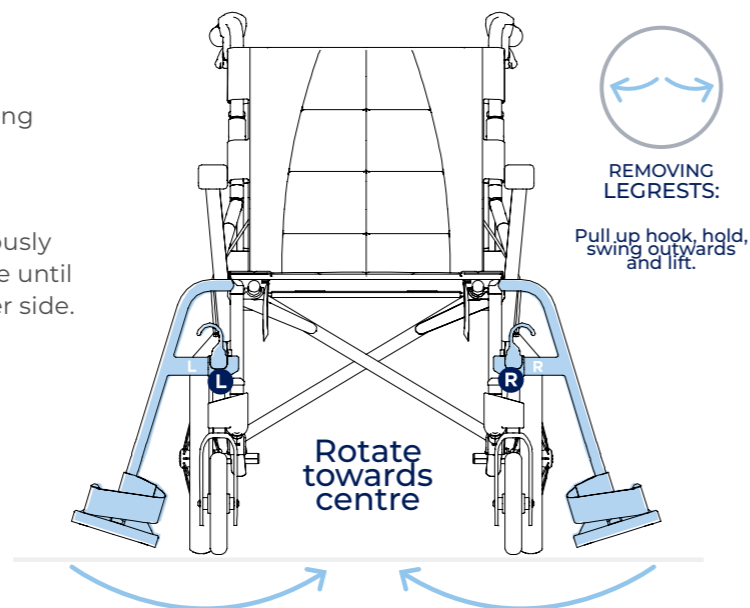

## 9. PRELIMINARY CHECKS

After assembling the wheelchair, these checks should be completed prior to initial use:

1. Check that the seating surface is locked into place, creating a flat support surface.
2. Check that rear wheels are locked in place.
3. Check that rear brakes engage and disengage.

## 10. GENERAL OPERATIONS

### General Operation

It is very important that this wheelchair is used under guidance from all warnings or hazards listed in this product user manual. Key safety measures should be taken by both users and attendants when using this wheelchair:

Avoid quick direction changes.

Ensure your wheelchair is used on surfaces intended for its use.

Ensure an attendant is available to assist at all times.

### Lifting the Wheelchair

To fold your chair correctly follow the 'ASSEMBLY' instructions in reverse **3, 2, 1**.

Then, use the carry handle on the seating surface to safely lift the wheelchair.



**DO NOT** lift the wheelchair with an occupant in the seat. This lifting guide is for safe handling of the wheelchair only.



**WARNING! DO NOT** lift the wheelchair by holding it by the legrests or the armrests! Fold-up the legrests prior to lifting the chair.

### Transporting the Wheelchair

To transport this chair in a motor vehicle it is suggested that the backrest, seat and legrests are folded as per the "Lifting the Wheelchair" instructions above. This will help reduce the overall chair size in order to fit into the rear boot or backseat of a standard motor vehicle.



**WARNING!** Aspire Socialite Wheelchairs are not crash tested and **SHOULD NOT** ever be used as a means of transporting a user in a motor vehicle.

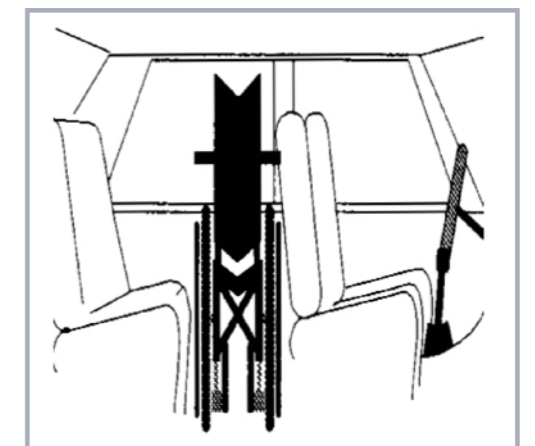
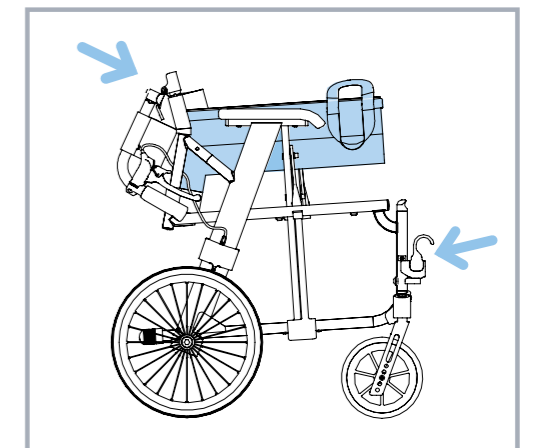

### Moving Wheelchair Up a Kerb - With an Attendant

1. Push the wheelchair up to the kerb FEET FIRST.
2. The attendant should push down on the rear foot peg to slightly incline the chair. DO NOT tilt the chair back with the push handles.
3. Once the front wheels are firmly on the ground above the kerb, the rear wheels should be pushed against the kerb to propel the entire chair to rest above the kerb.

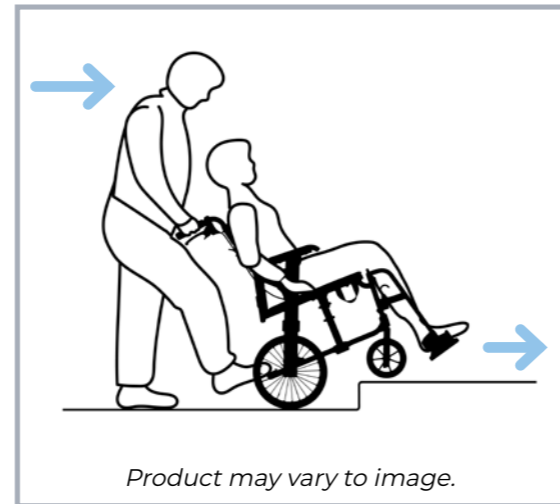

**WARNING!** This should only ever be done with an attendant and not performed by a user on their own. It is very important the above steps are followed to prevent injury to both the user and the attendant.

### Moving Wheelchair Down a Kerb - With an Attendant

1. Reverse the wheelchair up to the kerb FEET LAST.
2. The attendant should check for cars or obstructions prior to commencing the descent.
3. The attendant should slowly lower the rear wheels down to the road surface, ensuring not to tip the chair.
4. Once the rear wheels are firmly on the road surface, the front wheels should be slowly lowered onto the road surface

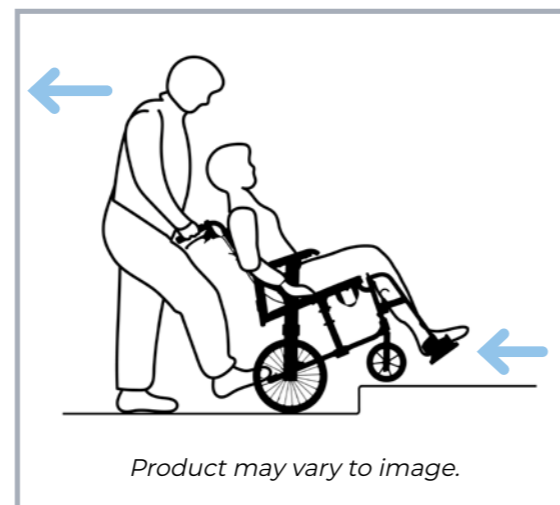

**WARNING!** This should only ever be done with an attendant and not performed by a user on their own. It is very important the above steps are followed to prevent injury to both the user and the attendant.

### ATTENDANT HANDBRAKE OPERATION

#### How to Activate Brakes

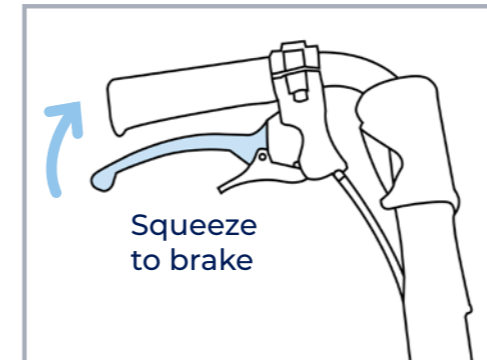

**BRAKE:** To engage brakes, squeeze the handbrake in an upwards direction.

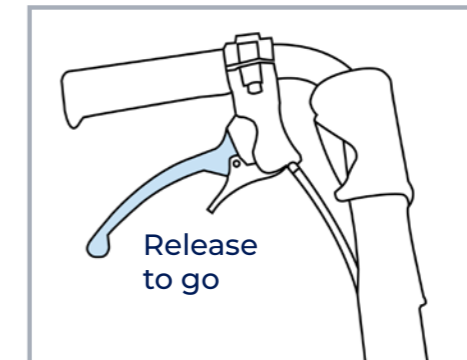

**RELEASE BRAKE:** To disengage brakes, release the handbrake.

#### How to Lock Brakes

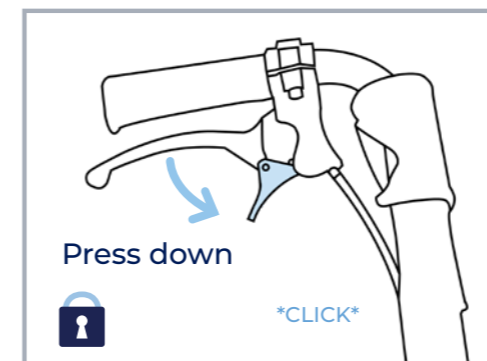

**LOCK:** To engage brakes, squeeze the handbrake in an upwards direction. Press down on the switch until it clicks, this will lock the brakes.

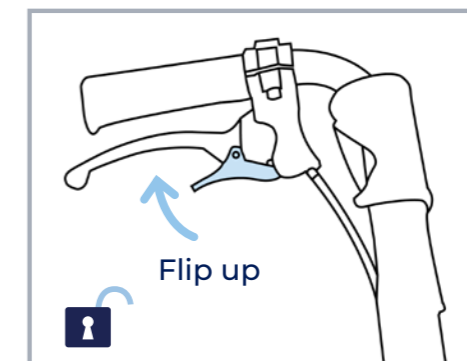

**UNLOCK:** To disengage brakes, flip the switch upwards.

## 11. ADJUSTING YOUR WHEELCHAIR

### ADJUSTING LEGREST HEIGHT

- 1 Using a 5mm Allen key loosen the bolt and remove the centre pin.



- 2 Nominate the preferred height by raising or lowering footplate.

- 3 To secure, align the centre pin with the chosen hole and tighten.

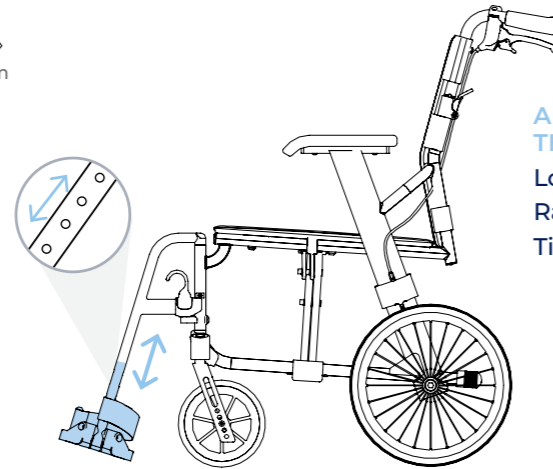

**ADJUSTING THE HEIGHT:**  
Loosen.  
Raise/Lower.  
Tighten.

### ADJUSTING SEAT ANGLE

- 1 Using a 4mm Allen key loosen the bolt and remove the centre pin.



- 2 Nominate the preferred seat angle by raising or lowering the castor.

- 3 To secure, align the centre pin with the chosen hole and tighten.

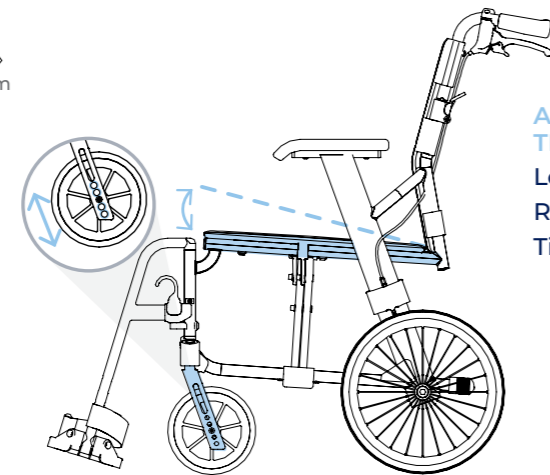

**ADJUSTING THE ANGLE:**  
Loosen.  
Raise/Lower.  
Tighten.

### REMOVING LEGRESTS

- 1 Pull up and hold the hook, simultaneously rotating the legrest (away from the centre of the chair) in an outwards direction until loose. Repeat for the other side.

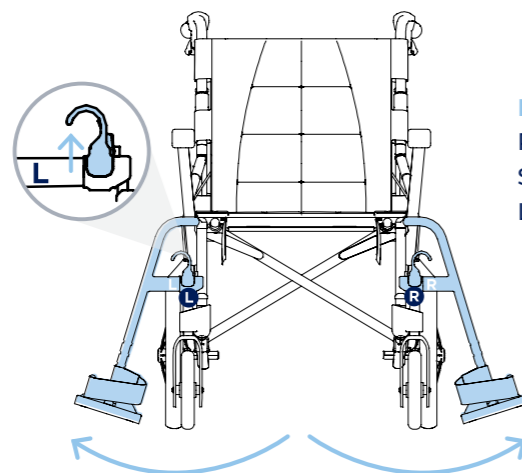

**REMOVAL:**  
Pull Up Hook & Hold.  
Swing Outwards.  
Lift to Remove.

## 12. OPTIONAL ACCESSORIES

### ANTI TIPPERS

WCA848270

#### Tools required:

Wrench (Included in box)

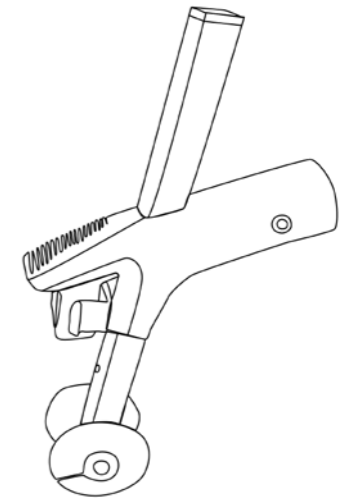

### Installing Anti Tippers

- 1 Twist and remove end cap (both sides).

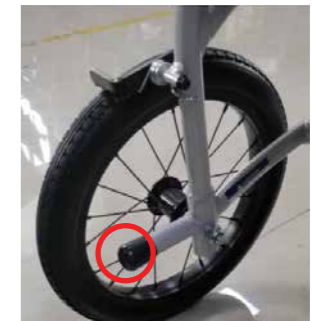

- 2 Remove bolt and nut from tipper. Slide tipper over tube. Place bolt through tipper and tube. Use the wrench to secure the nut.



- 3 The anti-tip wheel height range is adjustable for improved mobility during carer transportation.



## 13. TROUBLESHOOTING

<b>Wheelchair is steering/pulling to one side</b>	Make sure the rear wheels are attached correctly to the frame.
	Make sure the end user is able to evenly distribute his/her weight on the wheelchair.
	Make sure one wheel has not been mounted more tightly than the other.
<b>Wheelchair is moving slowly</b>	Make sure the rear wheels are attached correctly to the frame.
	Remove any hair or dirt from castor and rear wheel axles.
	Make sure there is not too much weight applied to the castors, otherwise adjust the centre of gravity.
	Ensure user clothing is not interfering with movement of the rear wheels.
<b>Wheelchair does not turn smoothly</b>	Ensure both brakes are disengaged.
	Make sure the front fork bolts are not over tightened which can restrict front castor wheel rotation.
	Remove any hair or dirt from castor axles.
<b>Brakes are not working properly</b>	Ensure both brakes are disengaged.
	Check distance between tyres and brake foot is sufficient such that the requisite amount of force can be applied to the tyre surface to stop it moving when the brake is in the engaged position.
<b>Wheelchair cannot be opened or folded easily</b>	Clean the crossbar under the seat and apply some grease.
	Check that nothing has become lodged under the seat or in and around the cross bar mechanism.
	Check foot plates are folded up.

Correct adjustment of the wheelchair is essential for the successful and safe use of this product.

Should assistance be required, contact the Aidacare Service Department on 1300 133 120.

## 14. CARE & MAINTENANCE

### MAINTENANCE SCHEDULE

Weekly	Periodically	Yearly	Serviceable Components
Check brakes are functioning properly	Check for signs of wear on front castors Check for signs of wear on rear tyres	Service to be completed by authorised Aspire service agent	Wheels & Tyres Forks Axles Armrest receivers Seat sling Footrest mounts Footplates Armrest Pads

### CARE FOR YOUR CHAIR

- Check tyre condition at least twice per month.
- Check that rear wheel spokes are not loose. Loose wheel spokes can reduce the strength of the rims and must be safely adjusted by a qualified technician.
- Always keep rear wheel axles clean and free from dirt and hair build up.
- Brakes should be checked regularly.

### CLEANING INSTRUCTIONS

- Clean the wheelchair regularly with a damp cloth.
- Use a mild washing agent and warm water for excess dirt build-up
- **DO NOT** use harsh abrasive or bleach-based agents which may cause damage or discolouration.
- **DO NOT** use the wheelchair if damages are found on the seat or backrest upholstery.
- Dry with a soft cloth

Should you have any doubts about the correct functioning of the wheelchair or any of its components, please contact Aidacare.



## 15. WARRANTY

---

**5 YEARS WARRANTY**  
Frame

**1 YEAR WARRANTY**  
Components

Aspire Vida Wheelchairs come with a 5-year warranty (frame) and a 1 year warranty (components).

Please keep purchase invoice as proof of warranty commencement.

This product carries a warranty that varies by component part. The frame and cross frame carry a 5-year warranty, and all other components except consumables (armrest pads, tyres, castors, and upholstery) carry a 1-year warranty. Consumable parts (armrest pads, tyres, castors and upholstery) carry a 1 year warranty against manufacturer defect only, and do not cover wear and tear through use.

For further information contact Aidacare.

## 16. COMPLIANCE

---

This Wheelchair range is manufactured in ISO compliant production facilities in P.R China to strict quality control standards.

Aspire wheelchairs are manufactured and independently tested to the market relevant compliance standards.

Labels on the wheelchair address compliance requirements and users should familiarise themselves with these prior to use.

## 17. SERVICE MAINTENANCE & CUSTOMISATION

---

**FOR ALL ENQUIRIES PLEASE CONTACT YOUR LOCAL AIDACARE BRANCH**

### 17.1 SPARE PARTS

Aidacare stock replacement parts for the Aspire wheelchair range. All replacement of parts should be completed by Aidacare or authorised Aspire service technician. The term parts includes but is not limited to: tyres, brakes, armrests, footrests and upholstery.

A complete parts list is available upon request.

### 17.2 CUSTOMISATION AND MODIFICATION

All wheelchair customisation, modifications and or alterations made to this product are considered as "custom" changes. These may cause the product to no longer meet safety standards and should be considered prior to commencement.

Any customisation or modification of the wheelchair is not warranted by Aidacare and will void warranty.

## 18. RECYCLING INFORMATION

---

Aspire Socialite Wheelchairs are made from metal and plastic components. The chair can be recycled via standard processes in your city of use.

## 19. MANUFACTURER, UK REPRESENTATIVE AND IMPORTER DETAILS

---

**If you have any questions, you can contact:**



**Manufacturer:**

**Aidacare Pty Ltd**

ABN 40 134 398 833

Building 3A, 1 Moorebank Avenue,  
Moorebank NSW 2170  
Australia

1300 133 120 | [product@aidacare.com.au](mailto:product@aidacare.com.au)

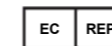

**EU Representative:**

**European Healthcare & Device Solutions (Ireland) Ltd**

Stratton House, Bishopstown Road  
Cork T12 Y9TC  
Ireland

[info@europeandevicesolutions.eu](mailto:info@europeandevicesolutions.eu)



**Importer:**

**Aidacare Ltd**

Registration 13785408

Arcadia House, Maritime Walk, Ocean Village, Southampton SO14 3TL  
United Kingdom

01622 541235 | [info@aidacare.co.uk](mailto:info@aidacare.co.uk)

NOTES

---

Series of horizontal lines for writing notes.

NOTES

---

Series of horizontal lines for writing notes.

**AIDACARE PTY LTD**

Building 3A, 1 Moorebank Avenue,  
Moorebank NSW 2170  
Australia

1300 133 120 | [aidacare.com.au](http://aidacare.com.au)

**AIDACARE LIMITED**

Arcadia House, Maritime Walk,  
Ocean Village, Southampton SO14 3TL  
United Kingdom

01622 541235 | [aidacare.co.uk](http://aidacare.co.uk)

MADE IN PRC

ASUM75.19 070524

